

**ASCOT**

**PRE-INSTALLATION REQUIREMENTS**

**Minimum Dimensions for Access: Doorway: - 825mm. Corridor: - 825mm**

**Consideration must be allowed to manoeuvre the bath around hallways etc**

**This document details the requirements which must be in place to ensure the bath can be installed correctly**

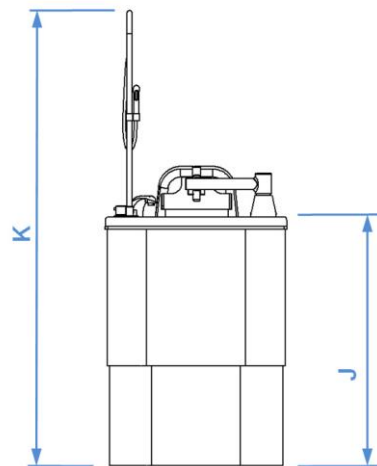
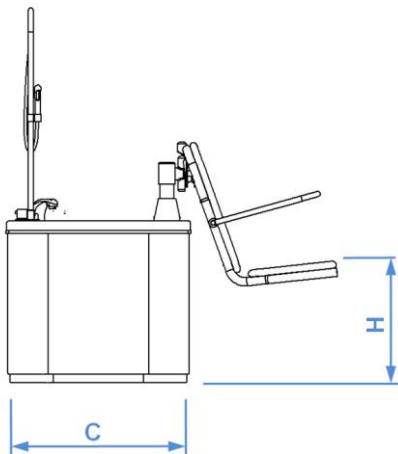
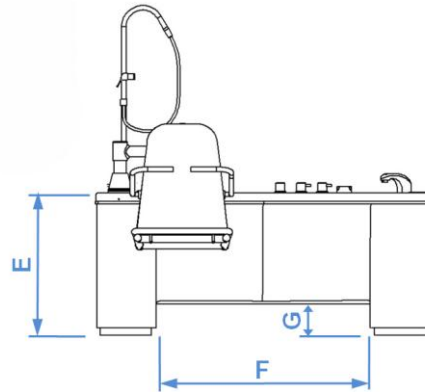
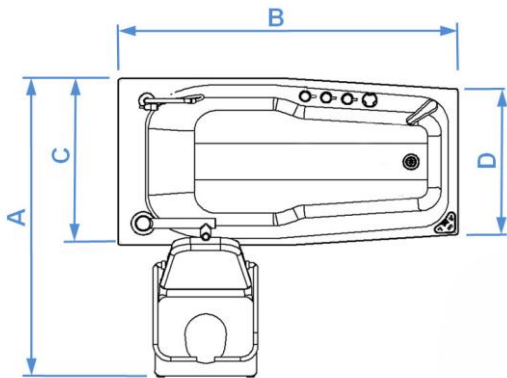

A = 1434mm	(56 1/2")
B = 1600mm	(63")
C = 800mm	(31 1/2")
D = 700mm	(27 1/2")
E = 685mm	(27")
F = 1020mm	(40 1/8")
G = 150mm	(6")
H = 515mm	(20 1/4")
J = 1085mm	(42 3/4")
K = 1985mm	(78 1/8")
L = 290mm	(11 3/8")

## INSTALLATION DETAILS

### RECOMMENDED MINIMUM DISTANCE BETWEEN WALLS AND BATH SIDES 150mm

#### Bath Positioning

When deciding on the positioning of the bath there are a number of points that should be taken into consideration:

1. Hoist/wheelchair access
2. Access for installation/Service/cleaning
3. Under floor pipe work or cabling
4. Conflict between bathroom door and bath seat when in out position
5. Distance from walls/other objects
6. Manoeuvring area transfer trolley

If you need further assistance in deciding on positioning please contact your representative for advice.

#### Access

Minimum dimensions for access purposes can be found on page 1  
Should it be required to reduce the weight of the bath in order to carry it upstairs please call the

#### SERVICE DEPARTMENT

#### Services Positioning

#### DIMENSIONS TAKEN FROM THE LEFT HAND SIDE OF THE BATH FRONT

1.  $\frac{3}{4}$ " BSP Male hot water inlet, 30mm from the floor, against the wall, 200mm from the left hand side of the front (tap end) of the bath.
2.  $\frac{3}{4}$ " BSP Male cold water inlet, 30mm from the floor, against the wall, 250mm from the left hand side of the front of the bath.
3. 40mm Waste outlet @ 3ltr/Sec, 30mm from the floor, against the wall, 290mm from the left hand side of the front of the bath.
4. XX 5 Amp IP65 Non Switch Fused Spur, with 2m of 1.5mm 3 core round cable protected inside plastic conduit to the bath within 200mm of the tap end of the bath, positioning and specification to be in accordance with IEE regulations.

#### Position of services to the bath

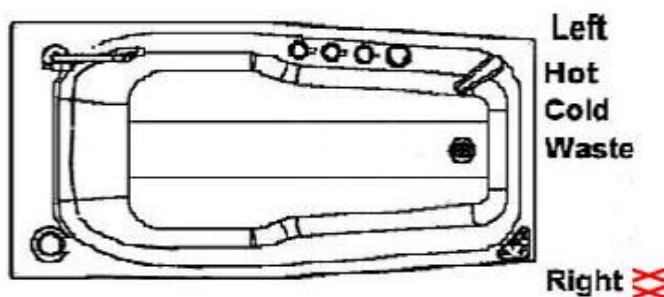

An additional power supply will be required if a spa is fitted.

A 13Amp IP rated non switched fused spur located within 200mm of the tap end of the bath, positioning and specification to be in accordance with IEE regulations.

Access to remove the covers to the power supply boxes must be considered when fixing to wall.

**PICTURE INDICATION ONLY  
TO THE SERVICE REQUIRED TO INSTALL THIS BATH**



**Floor Fixing Points**

<p>B = 1600 mm (63" )          F = 1020mm (40 1/8")          L = 290mm (11 3/8")</p>
--

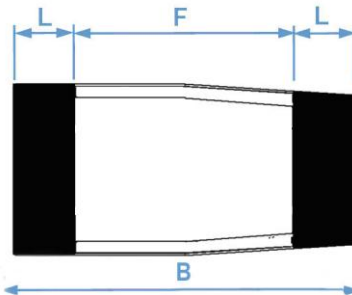

The floor directly under the bath must be a sound, solid and even surface. Particular attention should be paid to the shaded areas on the above plan which will be drilled to a depth of 100mm for fixing points, and must be of sound construction with no buried services.

**Electrical Connection & Earth Bonding**

A 30mA RCCD is required in compliance with current IEE regulations; this should be located just outside of the bathroom or on the consumer unit covering that area of the building.

**ALL CABLES FROM THE MAINS TO THE BATH MUST BE PROTECTED INSIDE CONDUIT**

It is important that the installer is made aware of the location of water stop cocks and mains electric RCD/trip switch on arrival to the property

**OPTIONAL:** 10mm Earth Bonding and a minimum of 4mm Cross Bonding is to be fitted and tested for continuity accordance with IEE regulations.

## Water Pressure Requirement

The Ascot bath includes a type 3 Heatguard Thermostatic Mixing Valve, which has been manufactured to NHS model engineering specification D08 and approved under the TMV3 scheme, please read the following which outlines how a TMV3 may effect the use of your bath.

The working parameters of the TMV3 require a water pressure of 1-5 bar with a maximum pressure loss ratio of no greater than 10:1 between hot and cold feeds.

It is important to note that a pressure difference between hot and cold pipes will have a great effect on the time it takes to fill a bath, i.e;

Hot water 1.4 bar and Cold water 2.4 bar = Approx. 9min. to fill bath with 180 litres  
Hot water 2.2 bar and Cold water 2.2 bar = Approx. 5min. to fill bath with 180 litres

If in doubt a pressure test should be carried out prior to installation of the bath, and if, required a booster pump or pressure reducing valves fitted.

## POWER BATH INSTALLATION KIT

Contents

M10 x 70mm	Sleeve Bolts	8
M8 x 70mm	Coach Screws	8
10 x 50mm	Nylon Plugs	8

The table below shows where each type of fixing should be used

Base Plate	Material
*Sleeve bolts	<b>Concrete</b>
M8 Coach Screws	<b>Joist &amp; Noggin</b>
M8 Coach Screws <b>With Nylon Plugs</b>	<b>Brick/Block</b>
*Sleeve bolts	<b>Compound Floor</b>
M8 Coach Screws <b>With Nylon Plugs**</b>	<b>Floating Floor</b>
M8 Coach Screws <b>With Nylon Plugs</b>	<b>Block &amp; Beam</b>

\*Sleeve bolts will not grip unless the hole is cleaned out first

\*\* Plugs to be fixed into lower section of floor and not floating section

**Should you experience difficulties please call  
our**

**Technical Support Line 0870 066 0809**